



ISO 12944:2018

Most important changes from ISO 12944:2007

www.zinga.eu



Content

- Introduction
- 12944-1: Durability
- 12944-2: Classification of environments
 - Atmospheric
 - Immersion
- 12944-3: Design considerations
- 12944-5: Protective paints systems
- 12944-9: Paint systems for offshore
- Certifications of ZINGA® as a unique systems
- Certifications of multiple layer systems



Introduction

ISO 12944 is one of the most **important international standards** for the **protection of steel against corrosion** by protective paints systems.



This presentation provides information about **the revision of the ISO 12944 standard**, showing the most relevant differences between the new (2018) and previous version (2007).

It also shows the **update in certifications** of ZINGA® unique & multiple layer systems



12944-1: Durability



Part 1 defines the overall scope and gives some basic terms and definitions, including the durability's.

Durability	Previous	NEW 
Low durability (L)	2 to 5 years	up to 7 years
Medium durability (M)	5 to 15 years	7 to 15 years
High durability (H)	More then 15 years	15 to 25 years
Very High durability (VH) 	-	More then 25 years



12944-2: Classification of environments

Part 2 deals with the classification of the principal environments to which steel structures are exposed. Those environments are based on the mass (or thickness) loss by standard specimens and describes typical natural environments. For atmospheric conditions:

Corrosion category - atmospheric		
C1 – Very Low		<i>No changes</i>
C2 - Low		<i>No changes</i>
C3 - Medium		<i>No changes</i>
C4 - High		<i>No changes</i>
C5-I Very high ^{industrial} C5-M Very high ^{Marine}	} C5 – Very High 	C5-I and C5-M are joined. C5 stands for offshore areas with high salinity AND aggressive industrial areas
 CX		This new category CX extreme is used for off-shore constructions (see Part 9)

12944-2: Classification of environments

The new category CX is for the extreme environment off-shore. There is a big difference between C5 and CX in terms of mass loss per unit surface / thickness loss.

Mass loss per unit surface/thickness loss after first year of exposure

Corrosion category	Low-carbon steel		Zinc	
	Mass loss (g/m ²)	Thickness loss (μm)	Mass loss (g/m ²)	Thickness loss (μm)
C5	> 650 to 1500	> 80 to 200	> 30 to 60	> 4,2 to 8,4
CX 	> 1500 to 5500	> 200 to 700	> 60 to 180	> 8,4 to 25



12944-2: Classification of environments

A new categorie for water and soil immersion

Category	Environment	Example/Explanation
Im1	Fresh water	River installations
Im2	Sea or brakish water	Immersed structures without cathodic protection
Im3	Soil	Buried tanks, buried piles
Im4 	Sea or brakish water	Immersed structures with cathodic protection



12944-3: Design considerations

The preparation grade shall be **P3** (ISO 8501-2) in case of **high and very high durabilities** for **C4, C5** and **CX** as well as **Im1 to Im4**. 

P3 is the highest grade of surface preparation. This is the responsibility of the steel constructor.

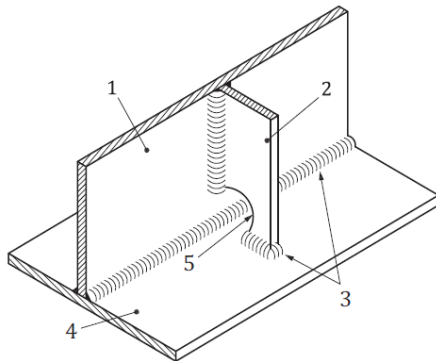

12944-5: Protective paints systems

Describes the types of paint and **paint system** commonly used for corrosion protection of steel structures.

It also gives **guidelines** for the selection of the most common & new innovative paint systems available for **different environments** (except for corrosivity category CX and category Im4) and the **durability grade** to be expected.

This document is **fully updated** to the **new durability's and categories**.



12944-9: Paint systems for offshore[★]

This **new document** specifies the performance requirements for **protective paint systems for offshore and related structures**. Such structures are exposed to environments of corrosivity category **CX** (offshore) and immersion category **Im4** (Sea or brakish water with cathodic protection). ISO 12944-9 is **replacing ISO 20340**.

This part of ISO 12944 describes paint systems for **high durability (> 15 year)** according to ISO 12944-1.



Certifications of ZINGA® as a unique system

OLD:

Layer thickness	Category	Durability	Neutral salt spray (h)
2 x 60 µm	C4	High	720
2 x 60 µm	C5I/M	Medium	720
2 x 90 µm	C5I/M	High	1440

NEW:

Layer thickness	Category	Durability	Neutral salt spray (h)	Cyclic ageing test (h)
ZINGA® 80 - 100 µm	C4 C5	High Medium	720	-
ZINGA® 120 µm	C5	Very High	-	2688
ZINGA® 120 µm	CX	High	-	4200
ZINGALU 110 µm	C4 C5	Very High High	1440	

Layer thickness	Category	Durability	Seawater immersion test (h)
ZINGA® 120 µm	Im4	High	4200

Certifications of multiple layer systems

System	Category	Durability	Neutral salt spray (h)	Water immersion
Zinga 60µm + Zingalufer 80µm	C5	High	1440	-
Zinga 60µm + Zingaceram HS 120µm	C5	High	1440	-
Zinga 60µm + Zingalufer 80µm + Zingaceram PU 60µm	C5	High	1440	-
Zinga 60µm + Zingaceram HS 120µm + Zingaceram PU 60µm	C5	High	1440	-
Zinga 60µm + Zingatarfree 2 x 100µm	Im2/3	High	1440	3000